

Comparison of Kalman and H ∞ filtering algorithm in the integrated navigation system

Wanxin Su*

Changchun Institute of Optics, Fine Mechanics and Physics, Chinese Academy of Sciences, East Nanhu Road No.3888, Changchun, China

Received 26 November 2014, www.cmnt.lv

Abstract

The integrated navigation (SINS/GPS) makes the output velocity or position difference between strap-down inertial navigation SINS and GPS as the measured values, and then the error of integrated navigation system is estimated and corrected by one filtering method in real time. In this paper, Kalman filtering algorithm and H ∞ filtering algorithm are compared by estimating the error, in colored noise conditions. It can be seen that Kalman filter estimate value error larger than H ∞ filter's, in the velocity and position of the three directions. Proved by simulation and experiment, H ∞ filtering algorithm has better stability and robustness.

Keywords: SINS/GPS, Kalman filtering, H ∞ filtering, algorithm navigation

1 Introduction

The Kalman filtering is an efficient recursive filter. Kalman filtering theory is obtained in Gauss white noise conditions of the state noise and observation noise. Kalman filter needs to give the accurate system state model and statistical characteristic of noise. When the system is of colored noise or modeling errors, the filter is easy to cause the divergence. Therefore, the system is not optimal estimation. H ∞ filtering algorithm has strong anti interference ability. Especially, when the colored noise or interference has unknown statistical properties, the system has good robustness. H ∞ filtering algorithm has become a new trend of modern navigation system.

In this paper, and Kalman filtering equation is given. H ∞ and Kalman filtering algorithm are compared. In colored noise, Kalman and H ∞ filtering algorithm is optimal error estimation and simulation. The results show that, H ∞ filtering algorithm is more suitable for SINS/GPS precision integrated navigation.

2 The Kalman filtering algorithm for SINS/GPS integrated navigation

2.1 SINS/GPS INTEGRATED NAVIGATION BASED ON KALMAN FILTER ALGORITHM

The strapdown inertial navigation SINS is undisturbed and has a strong autonomy, but long time working can bring on cumulative errors. Global positioning system (GPS) is more stable and has no cumulative working errors, but it is easily affected by obstacles. The advantages and disadvantages of the two speed up the integrated navigation of SINS/GPS. SINS and GPS integrated navigation makes the output difference between the two as the measured value to estimate the error value by one

filtering algorithm, SINS/GPS integrated navigation based on Kalman or H ∞ filter to realizing error compensation scheme is shown in Figure 1 below.

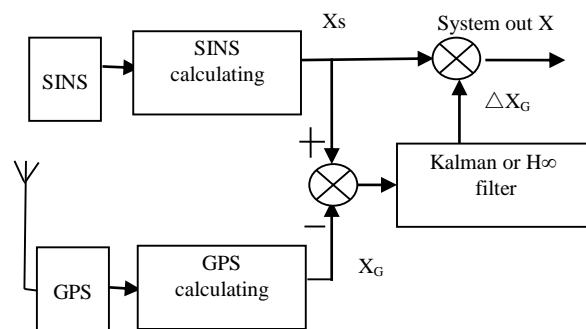

FIGURE 1 GPS/SINS integrated navigation based on Kalman filtering

2.2 KALMAN FILTER DESIGN

From Figure 1, it can be seen that the Kalman filter design in the system is the most important. In order to estimate the SINS errors more fully, the accelerometer errors of SINS $\nabla_E, \nabla_N, \nabla_U$ in three directions are also expressed as one state of system.

Based on the literature [1], the location error equations of SINS are as follows:

$$\begin{cases} \delta \dot{L} = \frac{\delta V_N}{R_M + h} - \delta h \frac{V_N}{(R_M + h)^2} \\ \delta \dot{\lambda} = \frac{\delta V_E}{R_N + h} \sec L + \delta L \frac{V_E}{R_N + h} \tan L \sec L - \delta h \frac{V_E \sec L}{(R_N + h)^2} \\ \delta \dot{h} = \delta V_U \end{cases} \quad (1)$$

* Corresponding author's e-mail:ccswx@163.com

Velocity error equations in three directions are as follows:

$$\begin{cases} \delta\dot{V}_E = f_N\phi_U - f_U\phi_N + \left(\frac{V_N}{R_N+h}\tan L - \frac{V_U}{R_N+h}\right)\delta V_E + \\ (2\omega_{ie}\sin L + \frac{V_E}{R_N+h}\tan L)\delta V_N - (2\omega_{ie}\cos L + \frac{V_E}{R_N+h})\delta V_U + \\ (2\omega_{ie}\cos L V_N + \frac{V_E V_N}{R_N+h}\sec^2 L - 2\omega_{ie}\sin L V_U)\delta L + \nabla_E \\ \delta\dot{V}_N = f_U\phi_E - f_E\phi_U - 2(\omega_{ie}\sin L + \frac{V_E}{R_N+h}\tan L)\delta V_E - \\ \frac{2V_N}{R_M+h}\delta V_U - 2(\omega_{ie}\cos L + \frac{V_E}{R_N+h}\sec^2 L)V_E\delta L + \nabla_N \\ \delta\dot{V}_U = f_E\phi_N - f_N\phi_E + 2(\omega_{ie}\cos L + \frac{V_E}{R_N+h})\delta V_E + \\ \frac{2V_N}{R_M+h}\delta V_U - 2\omega_{ie}\sin L V_E\delta L + \nabla_U \end{cases} \quad (2)$$

2.2.1 The establishment of the state equation

Accelerometer error $\nabla_E, \nabla_N, \nabla_U$ mainly contains zero bias $\nabla A_E, \nabla A_N, \nabla A_U$ and white noise $\omega_{AE}, \omega_{AN}, \omega_{AU}$ namely

$$\begin{cases} \nabla_E = \nabla A_E + \omega_{AE} \\ \nabla_N = \nabla A_N + \omega_{AN} \\ \nabla_U = \nabla A_U + \omega_{AU} \end{cases} \quad (3)$$

From Equations (1), (2), (3), it can get the state equation of the filter:

$$\dot{X}(t) = F(t)X(t) + W(t) \quad (4)$$

The state vector X contains nine state:

$$X = [\delta V_E, \delta V_N, \delta V_U, \delta L, \delta\lambda, \delta h, \nabla A_E, \nabla A_N, \nabla A_U]^T \quad (5)$$

$W(t)$ is the noise vector:

$$W = [\omega_{AE}, \omega_{AN}, \omega_{AU}, 0, 0, 0, 0, 0, 0]^T \quad (6)$$

Coefficient matrix F :

$$F = \begin{bmatrix} F_{b(6 \times 6)} & F_{s(6 \times 3)} \\ F_{G(3 \times 6)} & O_{(3 \times 3)} \end{bmatrix}_{9 \times 9} \quad (7)$$

$F_{b(6 \times 6)}$ is the coefficient matrix of inertial navigation error equation, $F_{s(6 \times 3)}, F_{G(3 \times 6)}$ is respectively

$$F_{s(6 \times 3)} = \begin{bmatrix} O_{(3 \times 3)} \\ I_{(3 \times 3)} \end{bmatrix} \quad (8)$$

$$F_{G(3 \times 6)} = \begin{bmatrix} \text{diag} \left[-\frac{1}{\tau_{SAVE}}, -\frac{1}{\tau_{SAVN}}, -\frac{1}{\tau_{SAVU}} \right] \\ \text{diag} \left[-\frac{1}{\tau_{SAL}}, -\frac{1}{\tau_{SA\lambda}}, -\frac{1}{\tau_{SAh}} \right] \end{bmatrix} \quad (9)$$

2.2.2 The establishment of the measurement equation.

Suppose $L_t, \lambda_t, h_t, V_{SEt}, V_{SNT}, V_{SUT}$ are the carrier the real position and speed, then the output position and speed can be represented as:

$$\begin{cases} V_{SE} = V_{SEt} + \delta V_E \\ V_{SN} = V_{SNT} + \delta V_N \\ V_{SU} = V_{SUT} + \delta V_U \\ L_S = L_t + \delta L \\ \lambda_S = \lambda_t + \delta \lambda \\ h_S = h_t + \delta h \end{cases} \quad (10)$$

The output of GPS position and velocity can be expressed as:

$$\begin{cases} V_{GE} = V_{SEt} + \omega_{SAVE} \\ V_{GN} = V_{SNT} + \omega_{SAVN} \\ V_{GU} = V_{SUT} + \omega_{SAVU} \\ L_G = L_t + \omega_{SAL} \\ \lambda_G = \lambda_t + \omega_{SA\lambda} \\ h_S = h_t + \omega_{SAh} \end{cases} \quad (11)$$

The input of the filter is positioning error difference between SINS and GPS. The input is defined as:

$$Z = \begin{bmatrix} V_{SE} - V_{GE} \\ V_{SN} - V_{GN} \\ V_{SU} - V_{GU} \\ L_S - L_G \\ \lambda_S - \lambda_G \\ h_S - h_G \end{bmatrix} = \begin{bmatrix} \delta V_E \\ \delta V_N \\ \delta V_U \\ \delta L \\ \delta \lambda \\ \delta h \end{bmatrix} - \begin{bmatrix} \omega_{SAVE} \\ \omega_{SAVN} \\ \omega_{SAVU} \\ \omega_{SAL} \\ \omega_{SA\lambda} \\ \omega_{SAh} \end{bmatrix} = H(t)X(t) + V(t) \quad (12)$$

Equation (12) constitutes the measurement equation of filter.

The Kalman filter state equation and measurement equation are constituted by (4) and (12). The continuous differential equations are transferred into discrete first-order differential equations as follows [2-3]:

$$\begin{cases} X_k = \Phi_{k,k-1} X_{k-1} + W_k \\ Z_k = H_k X_k + V_k \end{cases} \quad (13)$$

$\Phi_{k,k-1}$ is the system state transition matrix from $k-1$ to k . W_k, V_k is respectively discrete system noise and measurement noise. with this, we can get the discrete Kalman filter process [4].

Status first step forecast equation:

$$\hat{X}_{k/k-1} = \Phi_{k,k-1} \hat{X}_{k-1} \quad (14)$$

Status estimation forecast equation:

$$\hat{X}_k = \hat{X}_{k/k-1} + K_k (Z_k - H_k \hat{X}_{k/k-1}) \quad (15)$$

Optimal filtering gain equation:

$$K_k = P_{k,k-1} H_k^T (H_k P_{k,k-1} H_k^T + R_k)^{-1} \quad (16)$$

First step forecast average quadratic error:

$$P_{k/k-1} = \Phi_{k,k-1} P_{k-1} \Phi_{k,k-1}^T + \Gamma_{k-1} Q_{k-1} \Gamma_{k-1}^T \quad (17)$$

Estimating average quadratic error:

$$P_k = (I - K_k H_k) P_{k/k-1} \quad (18)$$

or

$$P_k = (I - K_k H_k) P_{k/k-1} (I - K_k H_k)^T + K_k R_k K_k^T \quad (19)$$

Γ_{k-1} is $n \times r$ rank system noise matrix. Q_k is the system noise quadratic matrix R_k is the measured noise matrix.

It can be seen that the Kalman filtering is a recursive arithmetic process. If the initial value of system state parameter is known, then the state at any time can be calculated.

3 SINS/GPS integrated navigation based on H^∞ filter algorithm

3.1 H^∞ filtering algorithm

Currently, H^∞ filtering algorithm as a kind of typical robust filtering method, is now attracting widespread attention. Compared with the traditional Kalman filtering method, H^∞ filtering doesn't need to know the system external noise prior knowledge and accurate mathematical model of the system. It is only required that the disturbance is bounded. Because the GPS assistant, system outside interference in general does not appear large range fluctuation. H^∞ filtering can be used on the system to estimate the speed and position error. The precision of integrated navigation system is improved by correcting the SINS error.

3.2 H^∞ FILTER DESIGN

According to the literature [5], for a nonlinear discrete system there are:

$$\begin{aligned} X_{k+1} &= f(X_k) + B_k W_k \\ Y_k &= C_k X_k + D_k V_k \\ Z_k &= L_k X_k \end{aligned} \quad (20)$$

Expand the nonlinear function $f(X_k)$ at $\hat{X}_{k,k}$ using Taylor series:

$$f(X_k) = f(\hat{X}_{k,k}) + \partial f / \partial X_k |_{x_k} = \hat{x}_{k,k} (X_k - \hat{X}_{k,k}) + O(X_k - \hat{X}_{k,k}) \quad (21)$$

Suppose:

$$\begin{cases} A_k = \partial f / \partial X_k |_{x_k} = \hat{x}_{k,k} \\ P_k = f(\hat{X}_{k,k}) - A_k X_k \\ S_k = O(X_k - \hat{X}_{k,k}) \\ \|S_k\|_2 = \delta^2 \|X_k - \hat{X}_{k,k}\|_2^2 \\ C_w^2 = C_v^2 = 1 + \gamma^2 \delta^2 \end{cases} \quad (22)$$

The system equation (20) can be rewritten as:

$$\begin{aligned} X_{k+1} &= A_k X_k + P_k + S_k + B_k W_k \\ Y_k &= C_k X_k + D_k V_k \\ Z_k &= L_k X_k \end{aligned} \quad (23)$$

H^∞ filtering is finally to design a filter, satisfying the performance index:

$$J = \|Z_k - \hat{Z}_k\|_2^2 < \gamma^2 (\|W_k\|^2 + \|V_k\|^2 + \|S_k\|^2) \quad (24)$$

That is to say, the estimation error is less than γ time of the noise. So that the estimation error can be limited at a lower level.

Considering the filter equation as follows:

$$\hat{X}(k+1) = A_k \hat{X}(k) + K_k [Y(k) - C_k A_k \hat{X}(k)] \quad (25)$$

Conclusion: there exists symmetric positive definite matrices P , make $J < \gamma^2$ satisfy Riccati Equation [6-7]:

$$\begin{aligned} P(k+1) &= (A_k - K_k C_k) H^{-1} (A_k - K_k C_k)^T + \\ & (B_k - K_k D_k) (B_k + K_k D_k)^T \\ K_k &= A_k H^{-1} C_k (D_k D_k^T + C_k H^{-1} C_k^T)^{-1} \\ H_k &= P^{-1}(k) - L / \gamma^2 \end{aligned} \quad (26)$$

When $\gamma \rightarrow \infty$, $H_k \rightarrow P^{-1}(k)$, the filter is transformed into Kalman filter.

When $\gamma \rightarrow \infty$, minimum variance estimation can be got, but it has the worst robustness.

When tends to be minimum, it can get the best robustness, but the variance is not minimum.

So it is necessary to select a proper γ . It can say that H^∞ filter is a Kalman filter which introduces an adjustable parameter γ .

4 The simulation results of the two filter algorithm

In colored noise environment, the initial reference data used in the simulation experiment [8-9] is as follows.

The initial position error:
 $\delta L_0 = \delta \lambda_0 = 0.001m$, $\delta h_0 = 0.01m$. The initial velocity error is $\delta V_{E_0} = \delta V_{N_0} = \delta V_{U_0} = 0.01m/s$. The accelerometer zero offset is

$\nabla A_E = \nabla A_N = \nabla A_U = 10 \times 10^{-6} g$. Inertial navigation platform error Angle is $\phi_e = \phi_n = \phi_u = 0.5'$. Adjustable parameters: $\gamma = 3$. The simulation time: $t=500s$.

4.1 THE SIMULATION RESULTS OF POSITION ERROR

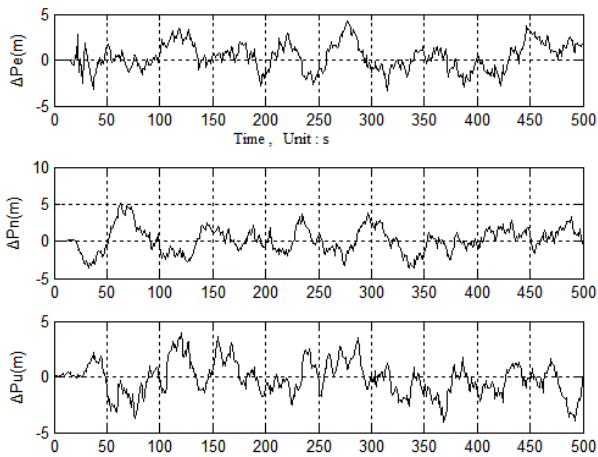

FIGURE 2 The position error estimated by Kalman filter algorithm

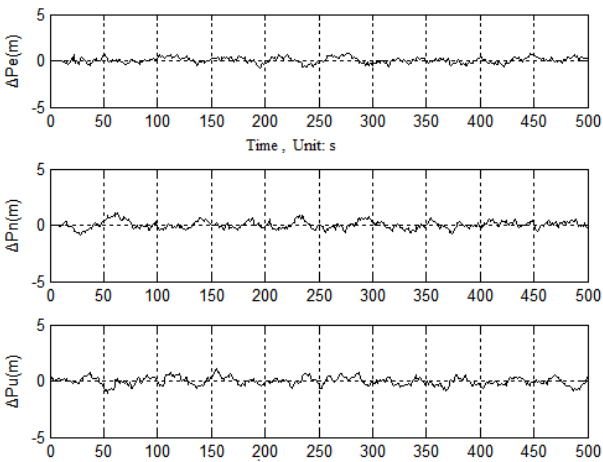

FIGURE 3 The position error estimated by H ∞ filter algorithm

4.3 THE RESULT ANALYSIS OF SIMULATION EXPERIMENT

See to Table 1-2, at the velocity and position of the three directions, Kalman filter estimate value error larger than H ∞ filter's. For example, Kalman filter velocity error estimates range up to 1.2m/s, H ∞ filter velocity error maximum is only 0.5m/s. The curve can be seen, in the three directions of the velocity and position, improved H ∞ filter error estimate value is very smooth. The Kalman filtering algorithm in the process of filtering is not stable, and the fluctuating range is very large.

4.2 THE SIMULATION RESULTS OF VELOCITY ERROR

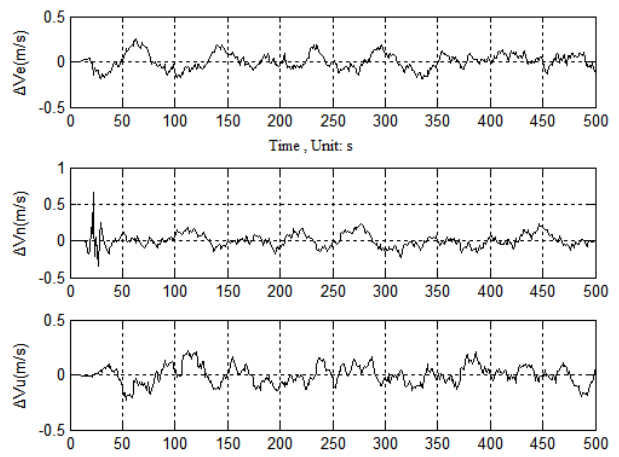

FIGURE 4 The velocity error estimated by Kalman filter algorithm

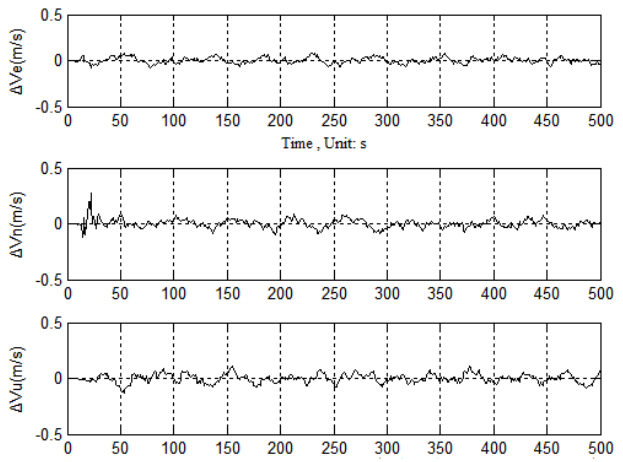

FIGURE 5 The velocity error estimated by H ∞ filter algorithm

TABLE 1 The velocity error estimated result

Velocity error (m/s)	Kalman filter	Improved H ∞ filter
Eastern velocity error ΔV_e	-0.208~0.187	-0.075~0.094s
North velocity error ΔV_n	-0.900~0.341	-0.410~0.126
Up velocity error ΔV_u	-0.252~0.203	-0.096~0.104

TABLE 2 The position error estimated result

Position error (m)	Kalman filter	Improved H ∞ filter
Eastern position error ΔP_e	-3.457~3.838	-0.754~1.085
North position error ΔP_n	-4.235~4.184	-0.921~0.981
Up position error ΔP_u	2.786~4.022	-0.972~0.790

5 Conclusion

Integrated navigation makes full use of the advantages of SINS and GPS. This paper, in colored noise conditions, using the Kalman filtering algorithm and H^∞ filtering algorithm, complete the navigation position and velocity error simulation experiment. The experiment results show

that, in the error estimation process, H^∞ filtering algorithm can suppress nonlinear noise better. Therefore, in integrated navigation system which is nonlinear, H^∞ filtering algorithm is superior to the traditional Kalman filter.

References

- [1] Liu P 2010 GPS/SINS integrated navigation system simulation research [D] *Changchun: changchun university of technology (in Chinese)*
- [2] Chen F, Wu X, Liu W 2014 On Kalman filtering under colored noise *Journal of XI'AN University of Posts and Telecommunications* **19**(2) 56-9 (in Chinese)
- [3] Zhang L, Zhang X, Chen Z 2013 Improvement of adaptive Kalman mtering algorithm and its application in SINS/GPS integrated navigation *Journal of Southeast University (Natural Science Edition)* **43**(1) 89-92 (in Chinese)
- [4] Su W-x, Huang C-m, Liu P-w 2010 Application of adaptive Kalman filter technique in initial alignment of inertial navigation system *Journal of Chinese Inertial Technology* **18**(01) 44-7 (in Chinese)
- [5] Zhao L, Wei Z-k, Liu S-b 2014 A Method to Design H^∞ Controller Based on the Velocity of GPS to Adjust Level Attitude Error of SINS *Missiles and Space Vehicles* (4) 28-31(in Chinese)
- [6] Song T, Wang H-L, Lu J-h 2011 H^∞ filter and its application in INS/CNS integrated navigation system *Electronic Design Engineering* **19**(1) 84-6 (in Chinese)
- [7] Nie L, Wu J, Tian H 2003 H^∞ filtering and its application in initial alignment of inertial navigation *Journal of Chinese inertial technology* **11**(6) 39-43 (in Chinese)
- [8] Wang J, Lee H K, Hewitson S, Lee H. Influence of Dynamics and Trajectory on Integrated GPS/INS Navigation Performance *Journal of Global Positioning Systems* **2**(2) 109-16 (in Chinese)
- [9] Goshen-Masking D, Bar-It hack I Y 2010 Absorbability Analysis of Piece-Wise Constant Systems-Part II: Application to Inertial Navigation In-Flight Alignment *IEEE Transactions on AES* **28**(4) 1068-75

Author



Su Wanxin, 1962.02.24, Henan, China.

Current position, grades: research professorship, Changchun Institute of Optics, Fine Mechanics and Physics, Chinese Academy of Sciences.

Scientific interest: inertial navigation, photoelectric measurement and control.

Publications: 15 papers.